

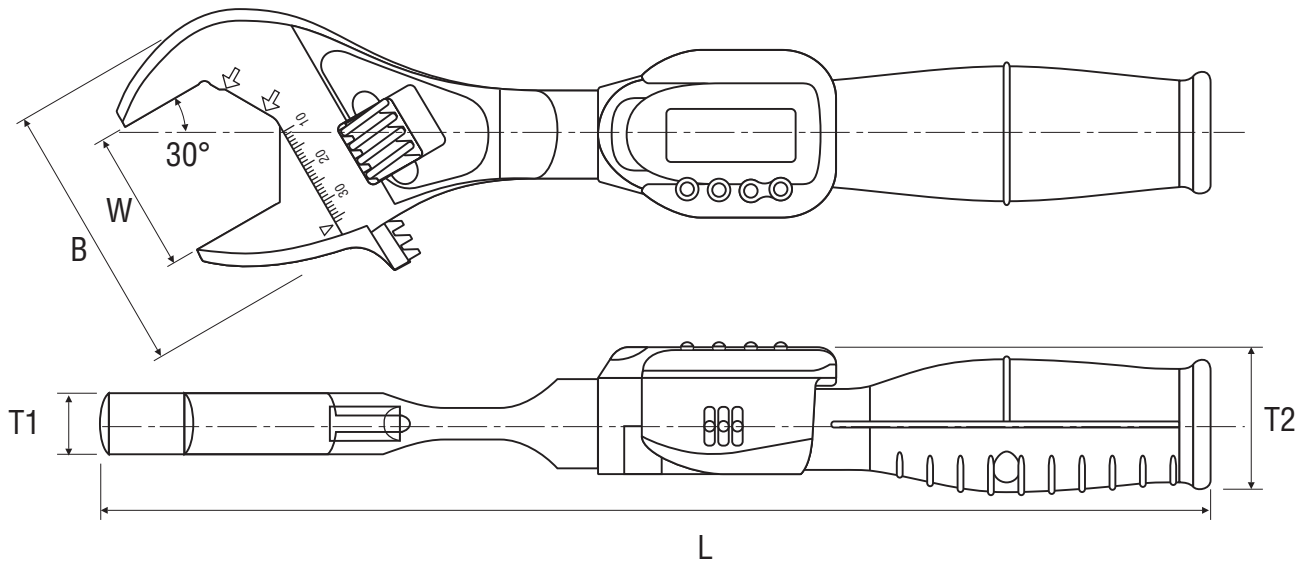

3100 Dundee Road, Suite707, Northbrook, IL 60062
 1-866-527-4666 | Fax: 847-564-2095
 www.hoto-instruments.com | E-mail: info@hoto-instruments.com
 ISO 9001 Certified and ISO/IEC 17025 Accredited

Digital Adjustable Torque Wrench Series GEK



Dimensions: millimeters (inches)

Model No.	W (mm)	B	L	T1	T2
GEK085-W36E	10~36 (.39~1.41")	69 (2.71")	275.2 (10.83")	14.5 (.57")	36 (1.41")
GEK135-W36E	10~36 (.39~1.41")	69 (2.71")	381.2 (15.00")	14.5 (.57")	36 (1.41")
GEK200-W36E	10~36 (.39~1.41")	69 (2.71")	581.2 (22.88")	14.5 (.57")	36 (1.41")